

Reg No.: _____

Name: _____

APJ ABDUL KALAM TECHNOLOGICAL UNIVERSITY

Fifth Semester B.Tech Degree Regular and Supplementary Examination December 2022 (2019 Scheme)

Course Code: CET 301**Course Name: STRUCTURAL ANALYSIS - I**

Max. Marks: 100

Duration: 3 Hours

PART A*(Answer all questions; each question carries 3 marks)*

Marks

- | | | |
|----|---|-----|
| 1 | Explain why it is assumed that 'loads are applied only at the joints' in the analysis of truss by method of joints. | (3) |
| 2 | State Moment- Area theorems. | (3) |
| 3 | Obtain the static and kinematic indeterminacies of a single span beam fixed at both ends. | (3) |
| 4 | Differentiate between force method and displacement method of analysis; give one example for each. | (3) |
| 5 | Write the basic equation used for Slope- Deflection method of analysis and explain each term. | (3) |
| 6 | Define Distribution Factor used in Moment- Distribution method. | (3) |
| 7 | A flexible cable hangs between supports A and B, which are at the same level and are 'L' distance apart. 'w' is the UDL supported by the cable, per unit span (L). Determine the support reactions. | (3) |
| 8 | Draw a neat sketch showing the different parts of a suspension bridge, indicating the load path. | (3) |
| 9 | Prove that a parabolic arch is funicular for a uniformly distributed load placed over the entire span. | (3) |
| 10 | Define Influence Line Diagram and list two uses of ILD. | (3) |

PART B*(Answer one full question from each module, each question carries 14 marks)***Module -1**

- | | | |
|----|--|------|
| 11 | a) Analyse the truss in Fig.1 by method of joints. | (10) |
|----|--|------|

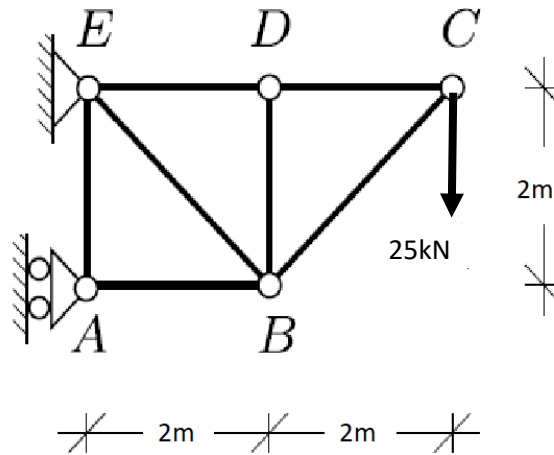

Fig.1

- b) Applying moment area theorem, obtain the slope and deflection at the free end of a cantilever beam of length L carrying a point load P at the free end. Flexural rigidity is EI . (4)
- 12 a) A simply supported beam AB of span 4.2m supports a uniformly distributed load of 10kN/m over the entire span and a concentrated load of 30kN at midspan. Using Castigliano's theorem, determine the deflection of the beam at midspan. Flexural rigidity is $EI= 350000\text{kNm}^2$. (10)
- b) Write in short about the method of sections for the analysis of plane truss. (4)

Module -2

- 13 a) Determine the vertical deflection at E of the pin jointed plane truss shown in Fig.2 using unit load method. All members have cross sectional area 1200mm^2 and $E= 200\text{GPa}$. $AB = BC= 3\text{m}$, $AF = 4\text{m}$. (10)

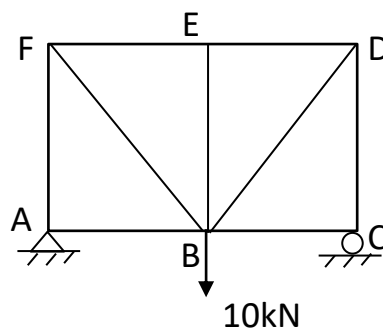

Fig.2

- b) Differentiate between the response of statically determinate structures and (4)

statically indeterminate structures to: i) temperature change, ii) support settlement.

- 14 a) Determine the support reactions in the beam shown in Fig.3 using method of consistent deformation. (11)

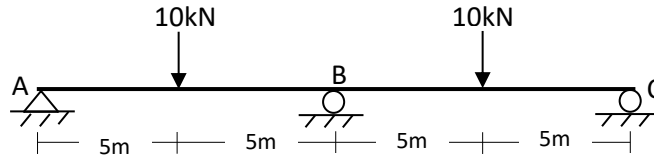

Fig.3

- b) State Maxwell's law of reciprocal deflection. (3)

Module -3

- 15 a) Analyse the frame shown in Fig.4 using slope- deflection method. EI is constant. (14)
Draw bending moment diagram.

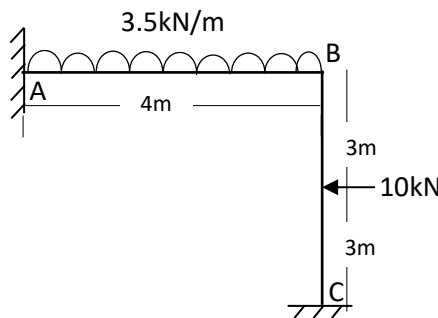

Fig.4

- 16 a) Analyse the continuous beam shown in Fig.5 using moment distribution method. (14)
Draw bending moment diagram and calculate support reactions. EI is constant.

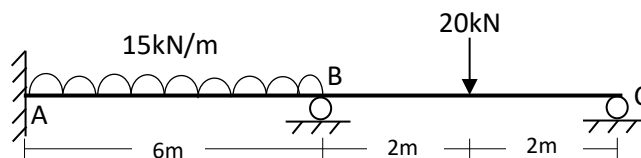

Fig.5

Module -4

- 17 a) A cable is suspended between two points A and B which are at the same level and 10m apart. The cable supports three point loads 15kN, 20kN and 12kN at (10)

points 2m, 4m and 7m from A. Dip of the point of suspension of the middle load is 4.2m. Determine the tension in the cable in different segments.

- b) Discuss the difference between guide pulley support and saddle support used for passing the cable of a suspension bridge on a supporting tower. (4)
- 18 a) Cable of a suspension bridge supports a uniformly distributed load of 10kN/m of horizontal span. Supporting piers are 20m high and 120m apart and dip of the cable is 18m. If the cable passes over frictionless pulley on top of the pier, determine the vertical and horizontal force transmitted to the pier and the maximum bending moment in the pier. Anchor cable is at 30° to the horizontal. (10)
- b) Prove that a freely suspended cable subjected to a UDL takes the shape of a parabola. (4)

Module -5

- 19 a) A three hinged parabolic arch of span 40m and central rise 12m supports uniformly distributed load of 3.5kN/m over the left half span. Determine the normal thrust and radial shear at point 3m from left support. (10)
- b) Draw ILD for the support reactions of a simply supported beam. (4)
- 20 a) A uniformly distributed load 40kN/m and 5m long traverses a simply supported beam AB of span 15m from left to right. Draw the influence line diagram for shear force and bending moment at a section 6m from A. Calculate the maximum shear force and bending moment at this section using these diagrams. (11)
- b) Draw the bending moment diagram of an arch of span L and central rise h carrying a concentrated load W at distance a ($a < L/2$) from the left support. (3)
