

Course Code: EST100

Course Name: ENGINEERING MECHANICS
(2019-Scheme)

Max. Marks: 100

Duration: 3 Hours

PART A

(Answer all questions, each carries 3 marks.)

- 1 State and explain Lami's theorem. (3)
- 2 What is meant by Free body diagram? Explain with an example. (3)
- 3 A small block of weight 1000 N as shown in Figure, is placed on a 30° inclined plane with $\mu = 0.25$. Determine the horizontal force to be applied for impending motion down the plane (3)

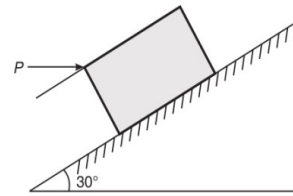

- 4 A rigid bar AD is acted upon by forces as shown in figure below. Reduce the force system to a single force- system and locate the point of application of the single force. (3)

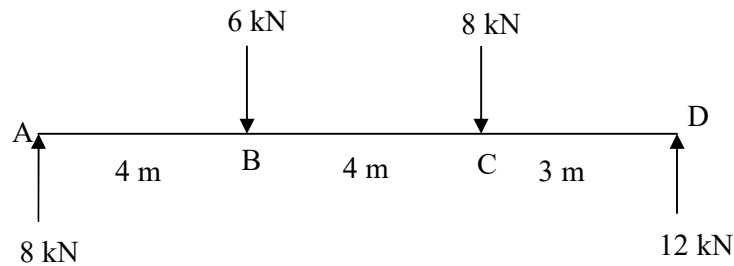

- 5 Find the moment about C(-2,3,5) of the force $F = 4\hat{i} + 4\hat{j} - 1\hat{k}$ passing through the point A (1,-2,4). (3)
- 6 Find the centre of gravity of lamina from O. (3)

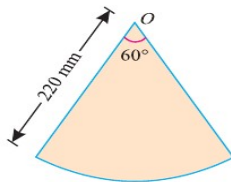

- 7 A 50 kg mass has a velocity of 10m/s horizontally on a smooth surface. Determine the magnitude of horizontal force required to bring the mass to rest in 5 seconds. (3)

- 8 A body is projected at an angle such that its horizontal displacement is 3 times that of maximum height. Find the angle of projection. (3)
- 9 A motor car is uniformly accelerated from 40 kmph to 50 kmph over a distance of 300m. If the wheels are 1 m diameter, find the angular acceleration of wheels. (3)
- 10 Differentiate between curvilinear motion and projectile motion. (3)

PART B

(Answer one full question from each module, each question carries 14 marks)

Module-I

- 11 a) A rope 9m long is connected at A and B, two points on the same level, 8m apart. A load of 300N is suspended from a point C on the rope 3m from A. What load connected to point D, on the rope, 2m from B is necessary to keep portion CD parallel to AB. (5)

- b) The resultant of a system of four forces is 5kN directed towards right along X-axis. Find the force P and its direction θ . (9)

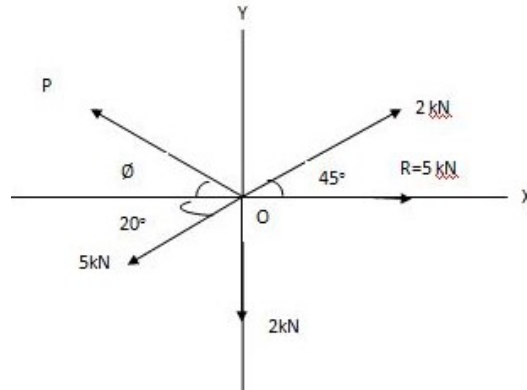

- 12 Three cylinders are piled in a rectangular ditch as in Fig. Neglecting friction, determine the reaction between cylinder A and vertical wall. (14)

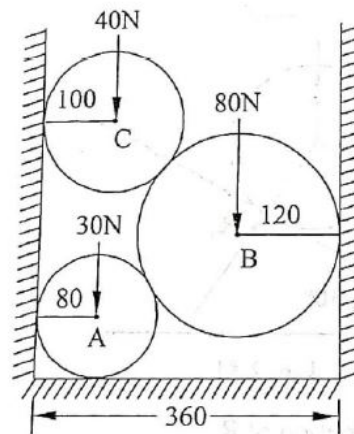

Module-II

- 13 a) A beam 6 m long is loaded as shown. Calculate the reactions at A and B. (7)

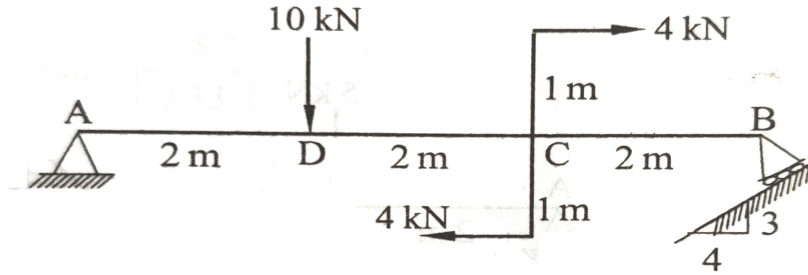

b) The uniform ladder is of mass 10kg and 2-m long, leaning against a vertical wall. The coefficient of static friction at A(wall) is 0.6 and at B (floor) is 0.4. Determine the smallest angle, for which the ladder can remain in the equilibrium. (7)

14 If the coefficient of static friction equals 0.3 for all surfaces of contact, determine the smallest value of force P necessary to raise the block A of mass 300kg. Neglect the weight of the wedge B. Angle of wedge is 10° . (14)

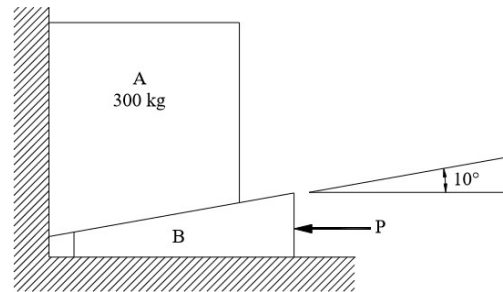

Module-III

15 Find the centroid of the shaded area shown. **Fig (Q15)** (14)

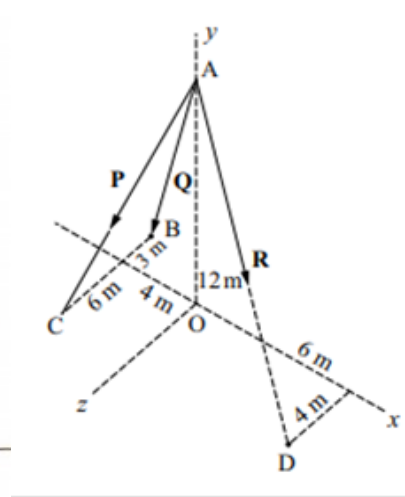
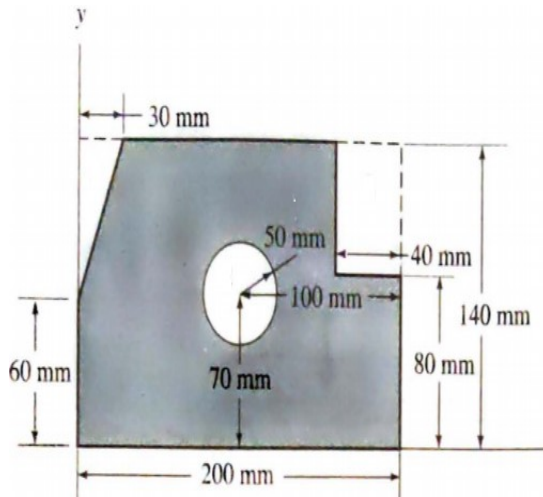

Fig (Q15)

Fig (Q16)

16 Find the resultant of the force system shown in Fig. in which $P = 280 \text{ N}$, $Q = 260 \text{ N}$ and $R = 210 \text{ N}$. **Fig (Q16)** (14)

Module-IV

17 Determine the tension in the inextensible string and the acceleration of the (14)

masses. Consider the pulley as massless and coefficient of friction as 0.20. Block A=200 kg and block B=100kg

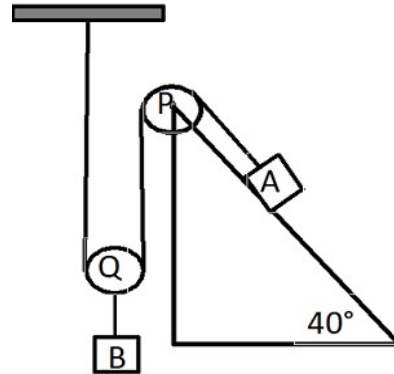

- 18 a) A glass ball is dropped on to a smooth horizontal floor from which it bounces to a height of 9m. On the second bounce, it rises to a height of 6m. From what height the ball was dropped and what is the coefficient of restitution between the glass and the floor? (5)
- b) Two cars A and B travelling in same direction get stopped at a traffic signal. When signal turns green, car A accelerates at 0.75 m/s^2 and 1.75 seconds later, car B starts and accelerates at 1.1 m/s^2 . Determine i) when and where B will overtake A and ii) the speed of each car at that time. (9)

Module-V

- 19 A circular disc of radius $r=30\text{cm}$ and weight $W=145\text{N}$ is free to rotate about its geometric axis. A flexible cord carrying a weight of $Q=45\text{N}$, is wound around the circumference of the disc as shown in Fig. If the weight Q is released from rest, find (a) the time t required for it to fall through the height $h=300\text{cm}$ (b) with what velocity v will it strike the floor? (14)

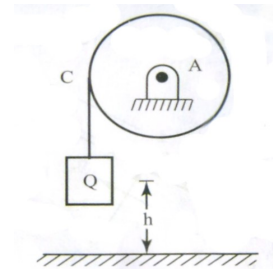

- 20 a) A 50N weight is suspended from a spring of constant $k=8 \text{ N/cm}$. Neglecting the mass of the spring, find the period for small amplitudes of vertical oscillations. (5)
- b) A particle performing Simple harmonic motion. When it is at distances of 10.0cm and 20.0cm from the mean position, its velocities are 1.2 m/s and 0.8 m/s respectively. Find (a) amplitude of oscillations. (b) time period of oscillations (c) its maximum velocity and (d) its maximum acceleration. (9)
